



PEGASUS CARTONER



Continuous Motion Cartoner

Features

- Compact Design
- Variable Speed
- Up to 7,200 CPH
(depending on carton size and other factors)
- Glue or Tuck Style Closure
- Broad Carton Size Range
- Simple Carton Size Change
- Optional Automatic Loading
- Stainless Steel Construction





2 Head Rotary Carton Erector



Optional Barrel Cam Product Loader

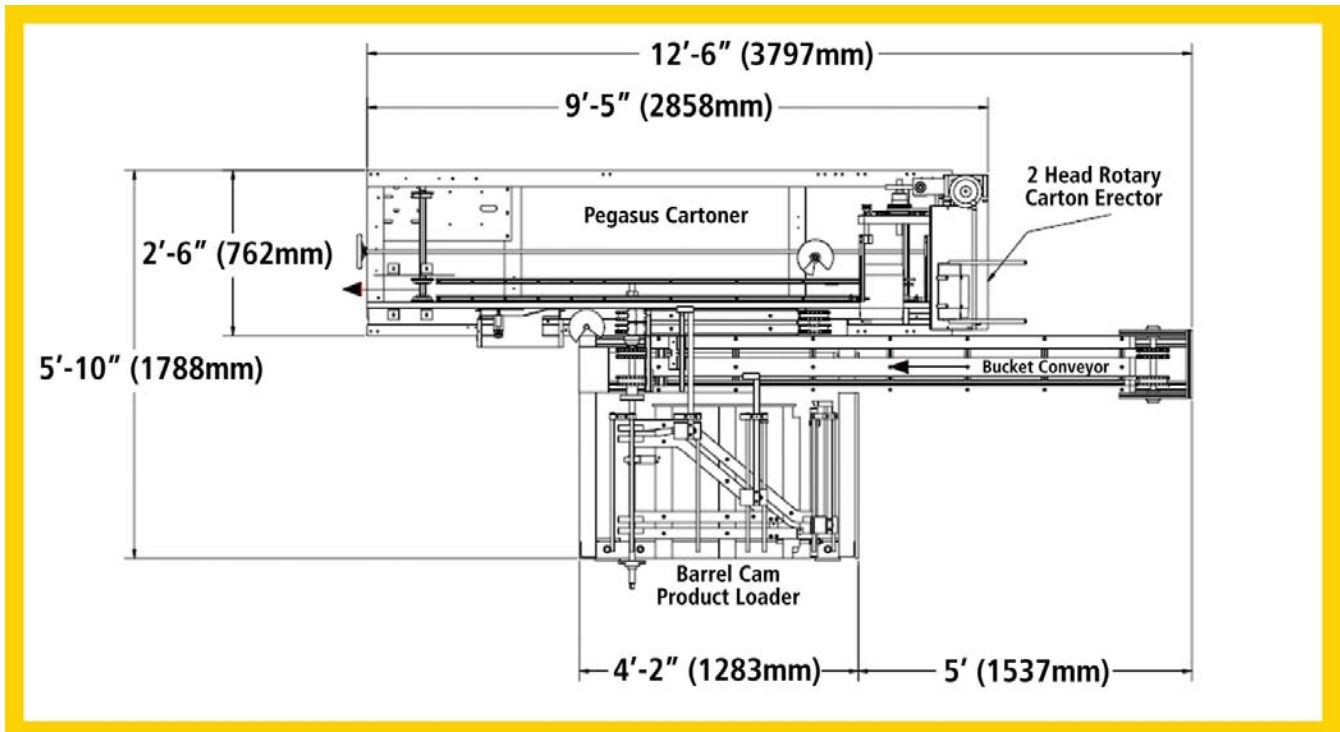

Pegasus Cartoner - ENGINEERING DETAILS

Size Range: (Carton Size)
 Min 2 x 1 x 4"
 (51 x 25 x 102mm)
 Max 8 x 3 x 12"
 (203 x 76 x 305mm)

Speed: Up to 7200 cartons per hour depending on carton size, style, and other factors.

Electrical: 220 volts, 50/60 Hz, Single Phase

Air: 80 psi (5,5 bar)
 Volume consumption approximately .5 CFM
 3 SCFM (12 Liters/min)

Shipping: 2400 lbs (1100 kg) (not including options)

All dimensions are approximate and subject to change.
 Machines can be quoted to handle cartons outside of range listed above upon request.



72 Pacella Park Drive, Randolph, MA 02368
 Telephone: +1 (781) 986-7500 Fax: +1 (781) 986-1553
 www.econocorp.com e-mail: info@econocorp.com

