

# ECONOSEAL<sup>®</sup>

## TWINSEAL



Twinseal shown with options of hand crank adjustment and delivery chute

### Economical carton sealer glues two flaps - size adjustment in minutes

- Carton size range:  
Min: 3/4 x 3/4 x 3" (19 x 19 x 76mm)  
Max: 12 x 4 x 12" (305 x 102 x 305m)
- Compact
- Speed: Up to 1800 cartons per hour (depending on operator dexterity, carton style, size and other factors)
- Simple operation with minimum moving parts

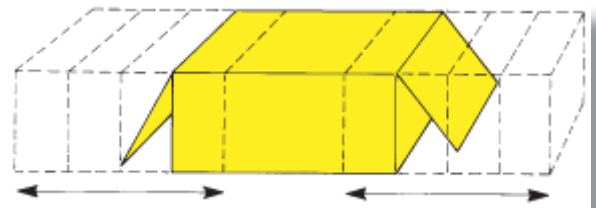

### Twinseal - Method of operation

1. Operator places loaded carton into the machine with inner flaps closed and presses dual button start.
2. Glue is automatically applied to underside of carton flap(s).
3. Carton is elevated into vertical squaring/compression chamber.
4. Completed, sealed cartons are automatically removed by the optional delivery chute accessory

## Sealing Method

### Hot Melt Glue

The hot melt glue system is the most popular Twinseal sealing method which minimizes flap compression time and works well with many different board materials and coatings.

### Hot Air Sealing

Hot air guns can be used to seal cartons that have either pre-applied adhesive or double sided sealable coatings on the carton board.

## Optional Equipment

### Hand Crank Lateral Adjustment

The Twinseal with hand crank adjustment was developed specifically for production lines that have multiple carton sizes and must switch back and forth to meet marketing demands. To change over to a new carton size, the hand crank is easily adjusted to the appropriate carton size and locked in position. Changeover time is reduced to minutes and most change parts are eliminated.

### Automatic Cycle

The Automatic Cycle option detects a carton in position for sealing and automatically starts the cycle.

### Coding (Auto-cycle option required)

Deboss, ink and hot leaf coding systems are available for installation on the Twinseal to meet your specific requirements.

### Automated Infeed Systems

Infeed conveyors are available to transport filled packages directly into the Twinseal without the need for an operator to feed loaded cartons directly into the Twinseal.



A row of fingers applies glue to the underside of the flap(s) to be sealed. This non-pressurized, open pot, glue finger system eliminates clogging.

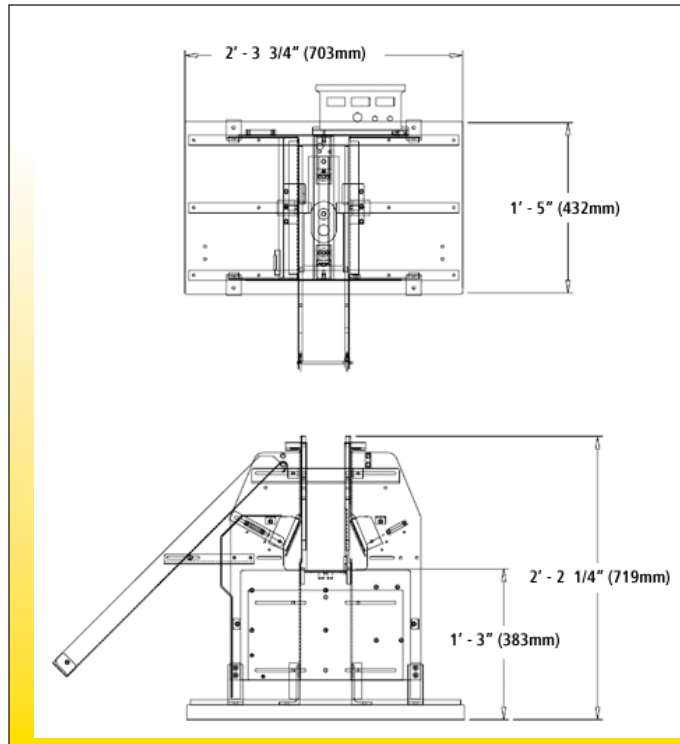

## TWINSEAL ENGINEERING DETAILS

<b>Size Range:</b>	(Carton Size) Min 3/4" x 3/4" x 3" (19 x 19 x 76mm) Max 12" x 4" x 12" (305 x 102 x 305mm)
<b>Speed:</b>	Up to 1800 cartons per hour depending on carton style, and other factors.
<b>Electrical:</b>	220 volts, 50/60 Hz, Single Phase 1400 Watt Hot Melt System
<b>Air:</b>	60 psi (4 bar) Volume consumption approximately 3.2 CFM 15.8 SCFM (30 Liters/min)
<b>Shipping:</b>	Normally less than 300 lbs (136 kg)

All dimensions are approximate and subject to change. Machines can be quoted to handle cartons outside of range listed above upon request.



72 Pacella Park Drive, Randolph, MA 02368  
Telephone: +1 (781) 986-7500 Fax: +1 (781) 986-1553  
www.econocorp.com e-mail: info@econocorp.com

