

# ECONOSEAL<sup>®</sup>

## SPARTAN CARTONER



Shown with optional 5' (1.5M) belt conveyor and product loader in opposite hand (RH) orientation.  
For standard hand (LH) orientation, see engineering layout on back.

### Rugged, Mechanical, Horizontal Cartoner

#### Features

- Sanitary construction (essentially stainless steel)
- Intermittent motion
- PLC controls
- Up to 2,400 cartons per hour (depending on carton style, size and other factors)

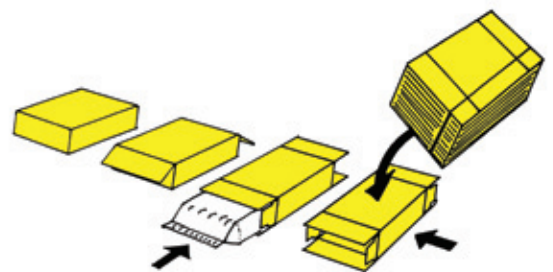

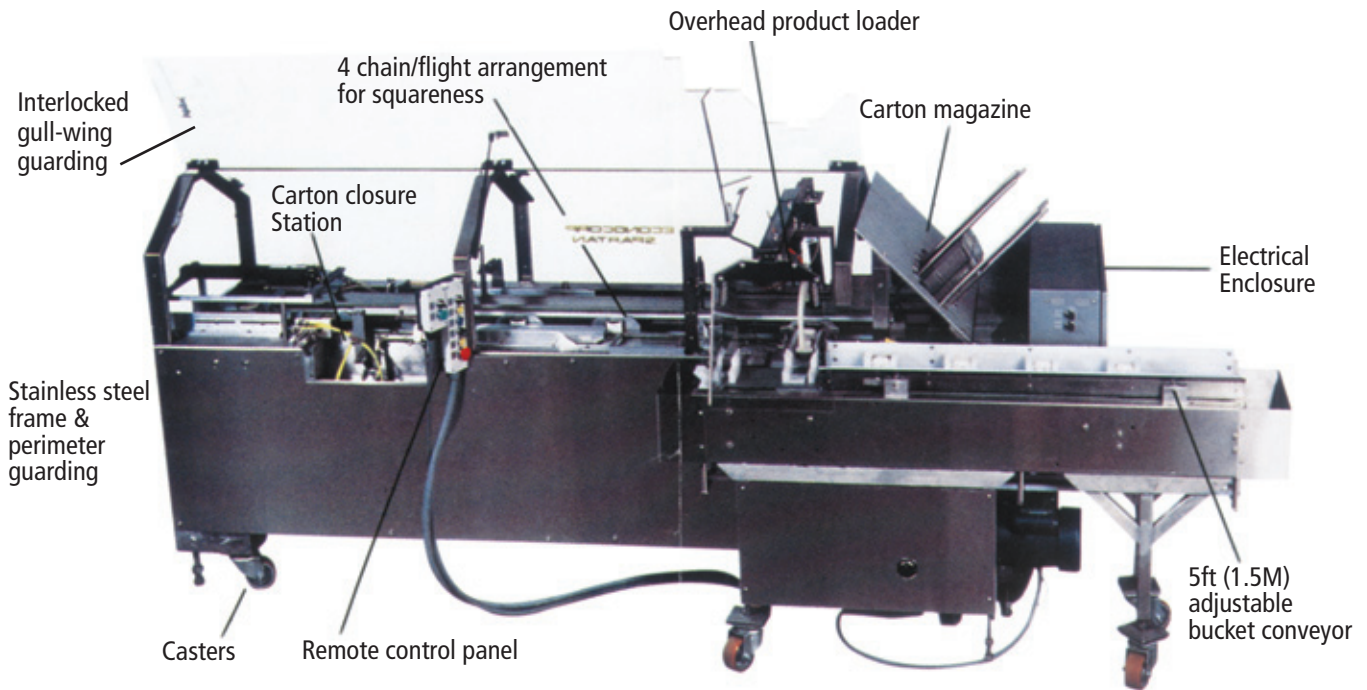

Shown above with optional 5' (1.5M) bucket conveyor and product loader in standard (LH) orientation.

## Spartan Cartoner - ENGINEERING DETAILS

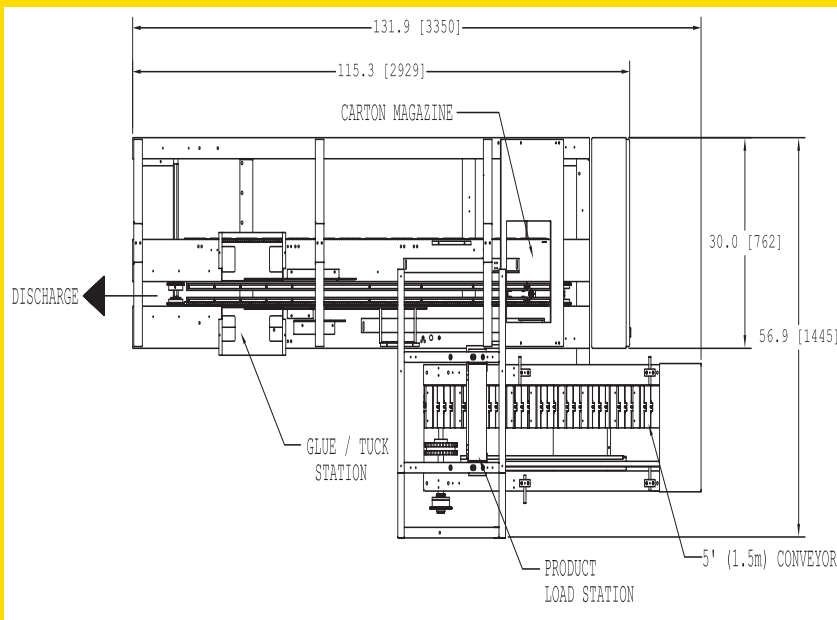

**Size Range:** (Carton Size)  
 Min 2" x 1" x 5"  
 (51 x 25 x 127mm)  
 Max. 10" x 4" x 12"  
 (254 x 102 x 305mm)

**Speed:** Up to 2400 cartons per hour depending on carton style, and other factors.

**Electrical:** 220 volts, 50/60 Hz, Single Phase

**Air:** 80 psi (5.5 bar)  
 Volume consumption approximately 1.6 CFM  
 8.5 SCFM (46 Liters/min)

**Shipping:** Normally less than 1900 lbs (860 kg)

All dimensions are approximate and subject to change.  
 Machines can be quoted to handle cartons outside of range listed above upon request.



72 Pacella Park Drive, Randolph, MA 02368  
 Telephone: +1 (781) 986-7500 Fax: +1 (781) 986-1553  
 www.econocorp.com e-mail: info@econocorp.com



Leading companies.  
 Leading solutions.